

Cu



2616
'PRESS GAS'

lok dvojni 90°

12	
15	
18	
22	
28	
35	
42	
54	

Cu



2616.1
'PRESS GAS'

lok enojni 90°

12	
15	
18	
22	
28	
35	
42	
54	

Cu



2616XL
'PRESS GAS'

XL lok dvojni 90°

64	92,42 €

Cu



2616.1XL
'PRESS GAS'

XL lok enojni 90°

64	84,30 €

Cu



2626
'PRESS GAS'

lok dvojni 45°

12	
15	
18	
22	
28	
35	
42	
54	

Cu



2626.1
'PRESS GAS'

lok enojni 45°

12	
15	
18	
22	
28	
35	
42	
54	

Cu



2626XL
'PRESS GAS'

XL lok dvojni 45°

64	

Cu



2626.1XL
'PRESS GAS'

XL lok enojni 45°

64	

Rg



2614
'PRESS GAS'

lok - zunanji navoj

12- ³ / ₈ "	
12- ¹ / ₂ "	
15- ¹ / ₂ "	
18- ¹ / ₂ "	
18- ³ / ₄ "	
22- ³ / ₄ "	
28-1"	
35-1 ¹ / ₄ "	
42-1 ¹ / ₂ "	
54-2"	

Rg



2614.2
'PRESS GAS'

koleno - notranji navoj

12- ³ / ₈ "	
12- ¹ / ₂ "	
15- ¹ / ₂ "	
15- ³ / ₄ "	
18- ¹ / ₂ "	
18- ³ / ₄ "	
22- ¹ / ₂ "	
22- ³ / ₄ "	
22-1"	
28-1"	
35-1 ¹ / ₄ "	
42-1 ¹ / ₂ "	
54-2"	

Cu

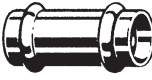

2615
'PRESS GAS'

spojka

12	
15	
18	
22	
28	
35	
42	
54	

Rg



2615.5
'PRESS GAS'

drsna spojka

15	
18	
22	
28	
35	
42	
54	

Cu



2615XL
'PRESS GAS'

XL spojka

64	

Cu



2615.5XL
'PRESS GAS'

XL drsna spojka

64	

Cu  2618 'PRESS GAS'

T - kos

12	
15	
18	
22	
28	
35	
42	
54	

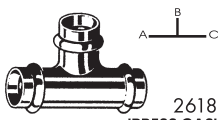
Cu  2618 'PRESS GAS'

reducirni T - kos

12-15-12	
15-12-12	
15-12-15	
15-15-12	
18-15-18	
22-12-22	
22-15-15	
22-15-22	
22-18-22	
22-22-15	
28-15-28	
28-18-28	
28-22-28	
35-22-35	
35-28-35	
42-22-42	
42-28-42	
42-35-42	
54-28-54	
54-42-54	

Rg  2611 'PRESS GAS'

prehodni kos zunanji navoj

12-3/8"	
12-1/2"	
15-1/2"	
15-3/4"	
18-1/2"	
18-3/4"	
22-1/2"	
22-3/4"	
22-1"	
28-3/4"	
28-1"	
28-1 1/4"	
35-1"	
35-1 1/4"	
35-1 1/2"	
42-1 1/4"	
42-1 1/2"	
54-1 1/2"	
54-2"	

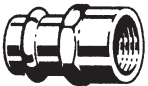
Rg  2612 'PRESS GAS'

prehodni kos notranji navoj

12-3/8"	
12-1/2"	
15-1/2"	
15-3/4"	
18-1/2"	
18-3/4"	
22-1/2"	
22-3/4"	
22-1"	
28-1"	
35-1 1/4"	
42-1 1/2"	
54-1 1/2"	
54-2"	

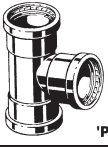
Cu  2618XL 'PRESS GAS'

XL reducirni T - kos

64	
64-54-64	

Cu  2615.1 'PRESS GAS'

reducirka "A"

15a-12	
18a-15	
22a-15	
22a-18	
28a-15	
28a-18	
28a-22	
35a-22	
35a-28	
42a-22	
42a-28	
42a-35	
54a-35	
54a-42	

Cu  2615.1XL 'PRESS GAS'

XL reducirka "A"

64a-42	
64a-54	

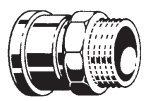
Rg  2611XL 'PRESS GAS'

XL prehodni kos zunanji navoj

64-2 1/2"	

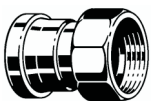
Rg  2612XL 'PRESS GAS'

XL prehodni kos notranji navoj

64-2 1/2"	

Cu  2656 'PRESS GAS'

kapa

12	
15	
18	
22	
28	
35	
42	
54	

Rg  2666 'PRESS GAS'

privijalo ravno tesnenje

15-1/2"	
18-1/2"	
22-3/4"	
28-1"	
28-1 1/4"	
28-1 1/2"	
35-1 1/2"	
42-2"	
54-2 1/2"	

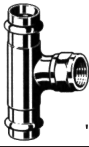
Rg  2617.2 'PRESS GAS'

T - kos - notranji navoj

15-1/2"-15	
18-1/2"-18	
22-1/2"-22	
22-3/4"-22	
28-1/2"-28	
28-3/4"-28	
35-1/2"-35	
35-1"-35	
42-1/2"-42	
42-1"-42	
54-1/2"-54	
54-1"-54	

Rg  2654 'PRESS GAS'

privijalo z.n.n. konično tesnenje

12-1/2"	
15-1/2"	
15-3/4"	
18-1/2"	
18-3/4"	
22-3/4"	
22-1"	
28-3/4"	
28-1"	
35-1 1/4"	
42-1 1/2"	
54-2"	

Fe  2624 'PRESS GAS'

montažna plošča

310 x 60	
----------	--

Rg  2614.6 'PRESS GAS'

pritrdilno koleno

22 x 3/4	
22 x 1	
28 x 1	

Rg  2625.5 'PRESS GAS'

kotni prehodni kos

12-1/2"	
15-1/2"	
18-1/2"	
22-3/4"	

Rg  2652 'PRESS GAS'

privijalo n.n.n. konično tesnenje

15-1/2"	
18-1/2"	
22-3/4"	
28-1"	
35-1 1/4"	
42-1 1/2"	
54-2"	

 G 2110 'PRESS GAS'

kroglični ventil

3/4"	
1"	
3/4" term.	
1" term.	

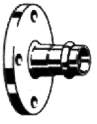
Rg  PN16 2659.5 'PRESS GAS'

prirobnica

(DN 25) 28	
(DN 32) 35	
(DN 40) 42	
(DN 50) 54	
(DN 65) 64	

 2646 'PRESS GAS'

PRESS kroglični ventil

15-1/2"	
18-1/2"	
22-3/4"	
28-1"	

RF  2259.7 'PRESS GAS'

prirobnični vijak - set

DN25/M12x65	
DN32-50/M16x70	
DN65-100/M16x70	

Rg  2650 'PRESS GAS'

privijalo dvojno konično tesnenje

15	
18	
22	
28	
35	
42	
54	